

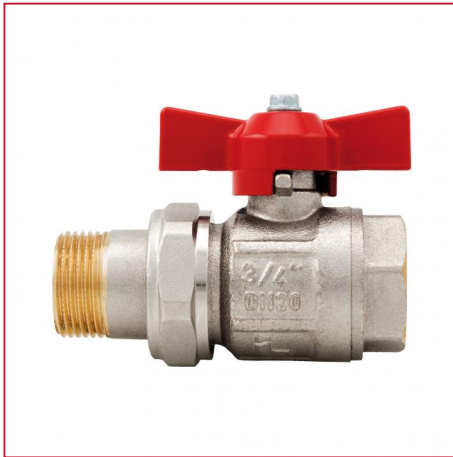

# FULL FLOW BALL VALVES: IDEAL

## 098 Ideal ball valve, full flow for manifolds

Suitable for domestic water services, heating and air-conditioning plants, compressed air systems.



MEASURE	PRESSURE	CODE	PACKING
1/2" (DN 15)	50bar/725psi	0980012	8/112
3/4" (DN 20)	40bar/580psi	0980034	6/54
1" (DN 25)	40bar/580psi	0980100	5/40
1"1/4 (DN 32)	30bar/435psi	0980114	3/27
1"1/2 (DN 40)	30bar/435psi	0980112	2/12
2" (DN 50)	25bar/362.5psi	0980200	2/10

### CERTIFICATIONS



### TECHNICAL SPECIFICATIONS

Male/female threads.

T handle in aluminium.

Body in nickel-plated brass.

Minimum and maximum working temperatures: -20°C, 150°C in absence of steam.

Threads: ISO 228 (equivalent to DIN EN ISO 228 and BS EN ISO 228).

1"1/2 and 2" size with flat seat and lever handle in steel.

### OVERALL DIMENSIONS

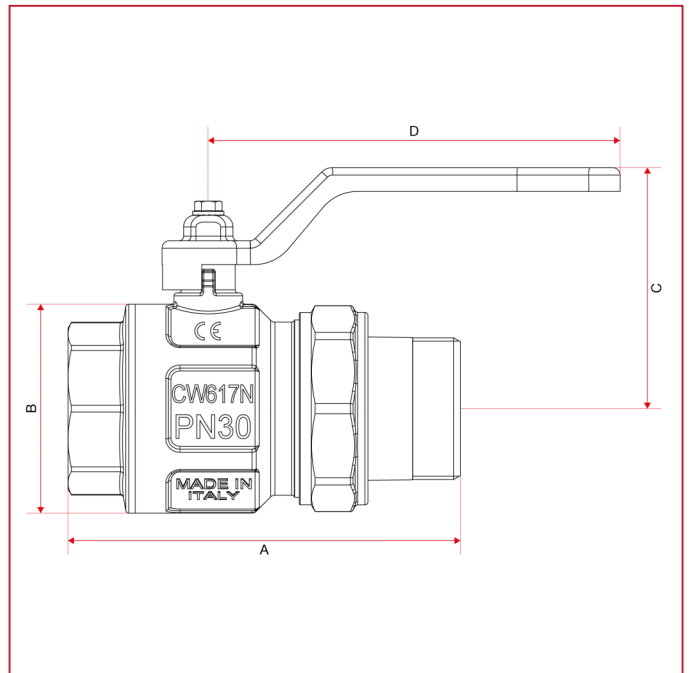
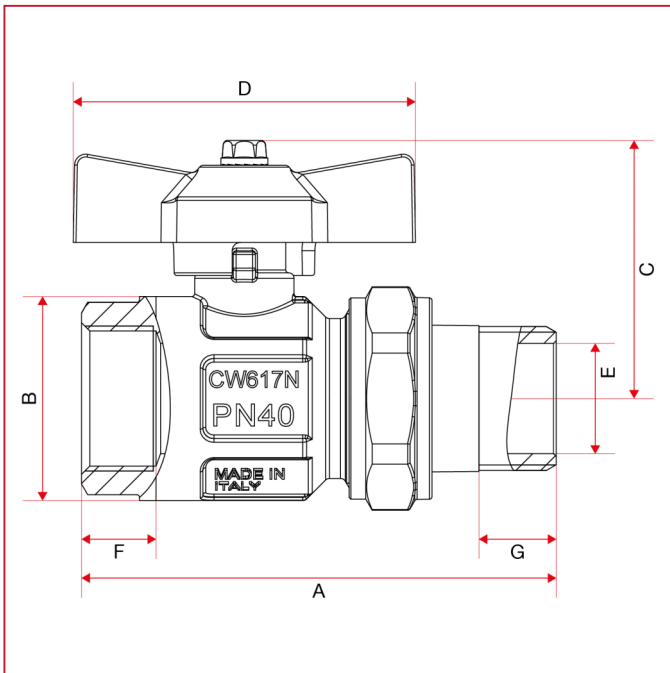



# FULL FLOW BALL VALVES: IDEAL

	1/2"	3/4"	1"	1"1/4	1"1/2	2"
DN	15	20	25	32	40	50
A	74	86	99	115	131,5	150,5
B	30,5	37	45,5	57	70	84
C	41	47	50,8	63,5	81	96
D	47	62	62	70	138	157,8
E	15	20	25	32	39	50
F	12,5	13,5	15	16,5	17,5	20,5
G	12	14	16	17	16	17
Kg/cm2 bar	50	40	40	30	30	25
LBS - psi	725	580	580	435	435	362,5

## MATERIALS sizes 1/2" through 1"1/4

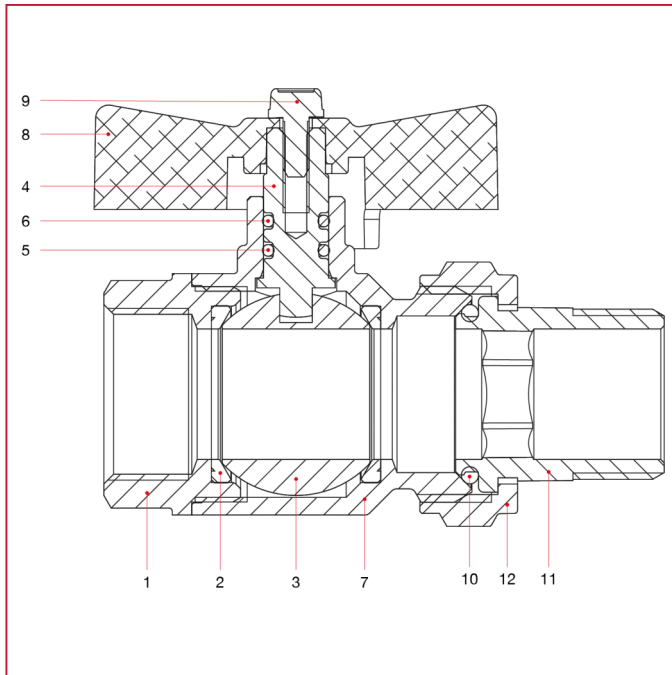

POS.	DESCRIPTION	N.	MATERIAL
1	Female end adapter	1	Nickel-plated brass CW617N
2	Seat	2	P.T.F.E.
3	Ball	1	Chrome-plated brass CW617N
4	Stem	1	Brass CW614N
5	O-ring	1	NBR
6	O-ring	1	Viton®
7	Body	1	Nickel-plated brass CW617N
8	T handle	1	Varnished aluminium
9	Screw	1	Zinc-plated steel C4C
10	O-ring	1	NBR
11	Union	1	Nickel-plated brass CW617N
12	Nut	1	Nickel-plated brass CW617N



# FULL FLOW BALL VALVES: IDEAL

**MATERIALS sizes 1"1/2 through 2"**

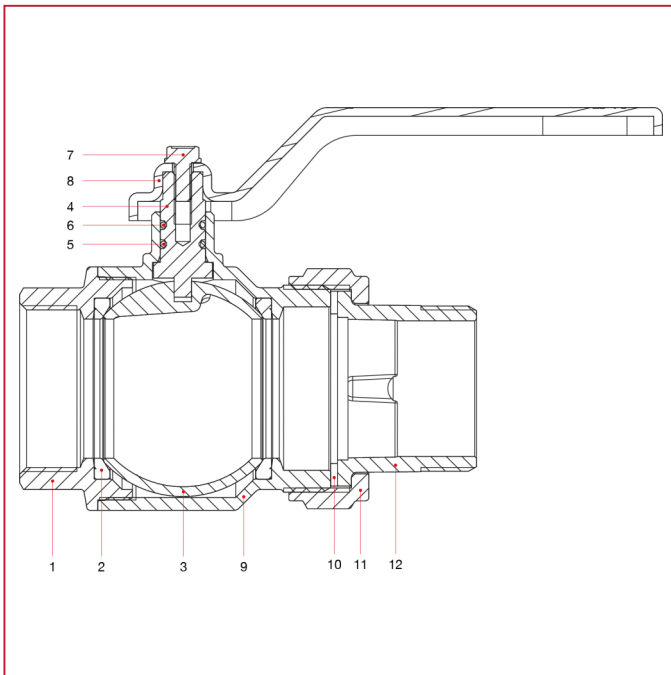

POS.	DESCRIPTION	N.	MATERIAL
1	Female end adapter	1	Nickel-plated brass CW617N
2	Seat	2	P.T.F.E.
3	Ball	1	Chrome-plated brass CW617N
4	Stem	1	Brass CW614N
5	O-ring	1	NBR
6	O-ring	1	Viton®
7	Screw	1	Zinc-plated steel C4C
8	Lever handle	1	Varnished steel P04
9	Body	1	Nickel-plated brass CW617N
10	Flat seat washer	1	NBR
11	Nut	1	Nickel-plated brass CW617N
12	Union	1	Nickel-plated brass CW617N



# FULL FLOW BALL VALVES: IDEAL

## INSTALLATION

The Itap S.p.A.'s valves are bi-directional, that means they manage the flow in both the directions.

The valves are composed by a ball, two seal in PTFE material, one stem, two sailing rings (O-Rings), one handle and a couple of parts made of brass (body and end adapter) that contain them and that are assembled by means of thread and a sealed material to obtain their aim.

In order to avoid that the sealed material gets broken and then the valve loses the connection between the body and the end-adapter, it's necessary to avoid to submit the two parts under the influence of a torque.

For the installation normal hydraulic practices must be used, and especially:

- ones have to be sure that the two pipes are correctly aligned;
- during the assembling process the installer has to apply its assembling tools at the end that is nearest to the pipe;
- the application of the sealing materials by the fitter (PTFE or hempen cloth) must be limited at the thread zone. An excess should interfere in the ball-gasket's closure zone, compromising the tightness.
- in the case that the fluid transported presents some impurities (dust, water too hard, etc.) ones have to remove these impurities by the means of a filter. Otherwise they could damage the seals.

## DISASSEMBLY

To remove the valve from the pipe line or anyhow before to unscrew the junctions linked to it:

- wear the clothing protective normally required to work with the fluid transported within the line;
- depressurize the line and operate in this way:
- positioning the valve in opened position and then empty the line;
- handle the valve to put down the residue pressure contained inside the space between the ball and the body before of remove it from the line;
- during the disassembly apply the screw tool at the end of the valve nearest the pipe;

## MAINTENANCE

Verify the valve periodically, according to its application's field and its works' field and its work's conditions, in order to be sure that the valve works correctly.