



TECHNICAL CATALOGUE

DIAPHRAGM SAFETY RELIEF VALVES *(DN15 e DN20)*



> THE COMPANY

ITAP SpA, founded in Lumezzane (Brescia) in 1972, is currently one of the leading production companies in Italy of **valves, fittings and distribution manifolds** for plumbing and heating systems.

Thanks to a fully automated production process, with 85 transfer machines and 55 assembly lines, it is capable of producing 400,000 pieces per day.

Our innate pursuit for innovation and observance of technical regulations is supported by the company certification ISO 9001. The company has always considered its focus on quality as the main tool to obtain significant business results: today ITAP SpA is proud to offer products bearing the approval of numerous international certifying bodies.

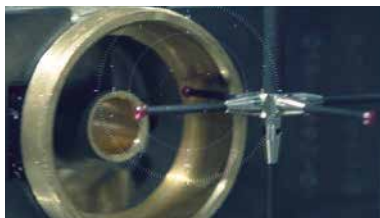
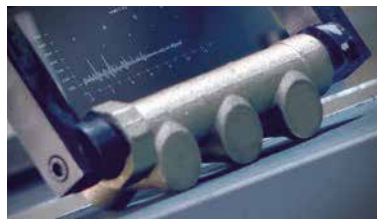
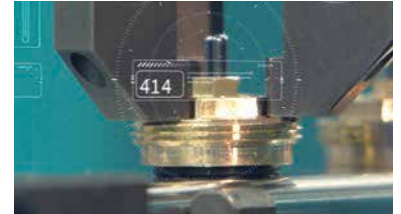

> ITAP products have obtained approvals by more than 30 certification bodies from all over the world.





DIAPHRAGM SAFETY RELIEF VALVES (DN15 e DN20)

DESCRIPTION

ITAP safety valves for heating and plumbing systems are essential devices designed to ensure system safety and proper operation.

The safety valve acts as an emergency relief valve, operating only when needed to **protect** the system and **prevent serious damage**.

The valves comply with the "PED" Directive 2014/68/EU (Cat. IV). (DN15–DN20)



AVAILABLE MODELS

368 Diaphragm safety relief valve, female/female thread



368 1/2"x1/2"

MEASURE	PRESSURE	CODE	PACKING
1/2" (DN 15)	1.5	368001215	10/120
1/2" (DN 15)	1.8	368001218	10/120
1/2" (DN 15)	2.5	368001225	10/120
1/2" (DN 15)	3	368001230	10/120
1/2" (DN 15)	4	368001240	10/120
1/2" (DN 15)	6	368001260	10/120

368 3/4"x3/4"

MEASURE	PRESSURE	CODE	PACKING
3/4" (DN 20)	1.5	368003415	10/120
3/4" (DN 20)	1.8	368003418	10/120
3/4" (DN 20)	2.5	368003425	10/120
3/4" (DN 20)	3	368003430	10/120
3/4" (DN 20)	4	368003440	10/120
3/4" (DN 20)	6	368003460	10/120

369 Diaphragm safety relief valve, male/female thread



369 1/2"x1/2"

MEASURE	PRESSURE	CODE	PACKING
1/2" (DN 15)	1.5	369001215	10/120
1/2" (DN 15)	1.8	369001218	10/120
1/2" (DN 15)	2.5	369001225	10/120
1/2" (DN 15)	3	369001230	10/120
1/2" (DN 15)	4	369001240	10/120
1/2" (DN 15)	6	369001260	10/120



DIAPHRAGM SAFETY RELIEF VALVES (DN15 e DN20)

368M Diaphragm safety relief valve with pressure gauge connection, female/female thread



368M 1/2"x1/2", gauge connection 1/4"

MEASURE	PRESSURE	CODE	PACKING
1/2" (DN 15)	1.5	368001215M	10/120
1/2" (DN 15)	1.8	368001218M	10/120
1/2" (DN 15)	2.5	368001225M	10/120
1/2" (DN 15)	3	368001230M	10/120
1/2" (DN 15)	4	368001240M	10/120
1/2" (DN 15)	6	368001260M	10/120

369M Diaphragm safety relief valve with pressure gauge connection, male/female thread



369M 1/2"x1/2", gauge connection 1/4"

MEASURE	PRESSURE	CODE	PACKING
1/2" (DN 15)	1.5	369001215M	10/120
1/2" (DN 15)	1.8	369001218M	10/120
1/2" (DN 15)	2.5	369001225M	10/120
1/2" (DN 15)	3	369001230M	10/120
1/2" (DN 15)	4	369001240M	10/120
1/2" (DN 15)	6	369001260M	10/120

TECHNICAL SPECIFICATIONS

Working fluid: water, air.

PED category: IV.

Opening overpressure: 20%.

Closing deviation: 20%.

Nominal pressure: 10 bar.

Operating temperature: 5°C to 115°C.

Available settings: 1.5 – 1.8 – 2.5 – 3 – 4 – 6 bar.



DIAPHRAGM SAFETY RELIEF VALVES (DN15 e DN20)

OVERALL DIMENSIONS

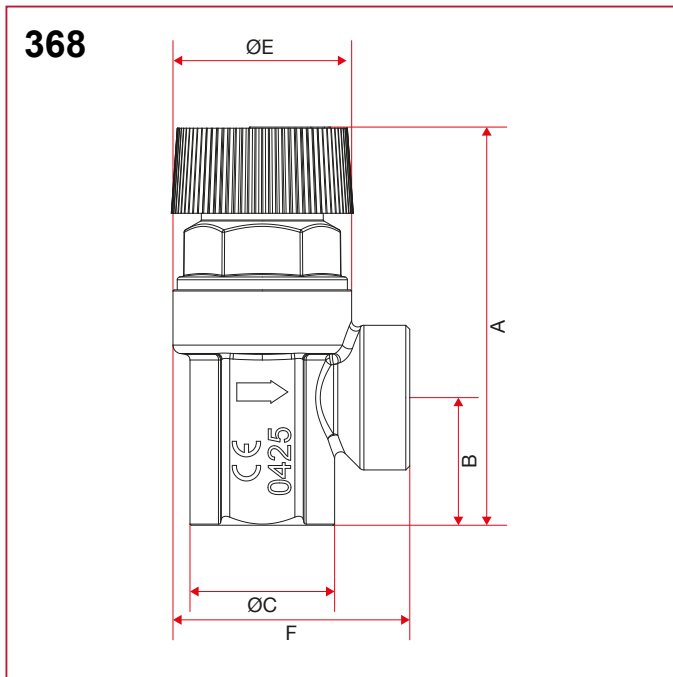

	1/2"	3/4"
A	70	75
B	22,5	26,5
C	25,5	25,5
E	31,5	32
F	41,75	46

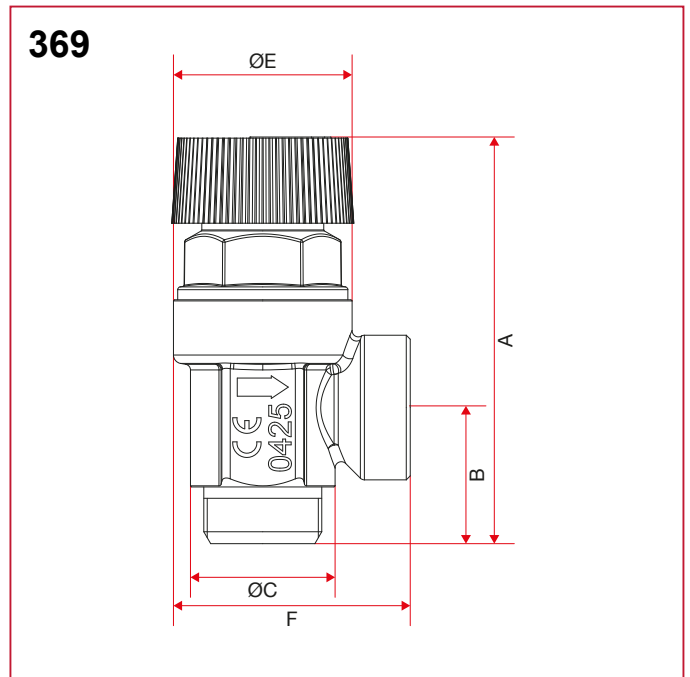

	1/2"
A	71,5
B	24
C	25,5
E	31,5
F	41,75

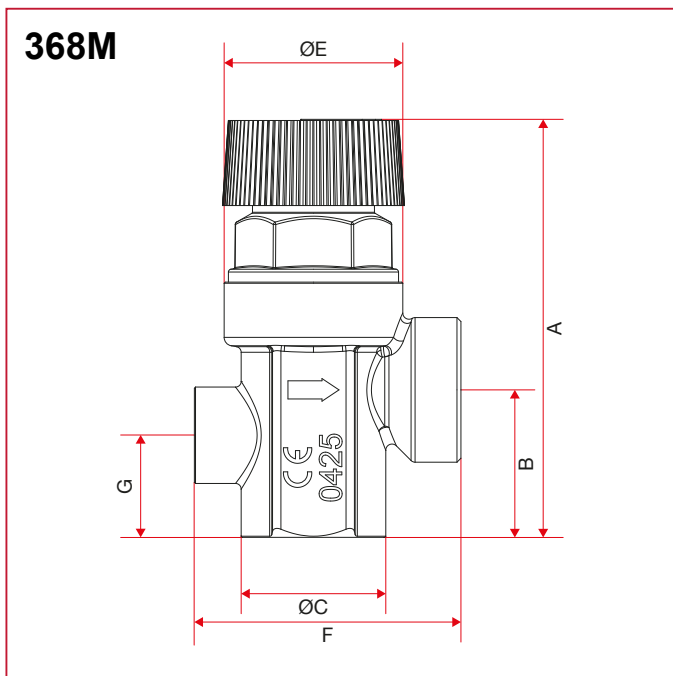

	1/2"
A	73,5
B	26
C	25,5
E	31,5
F	47
G	18

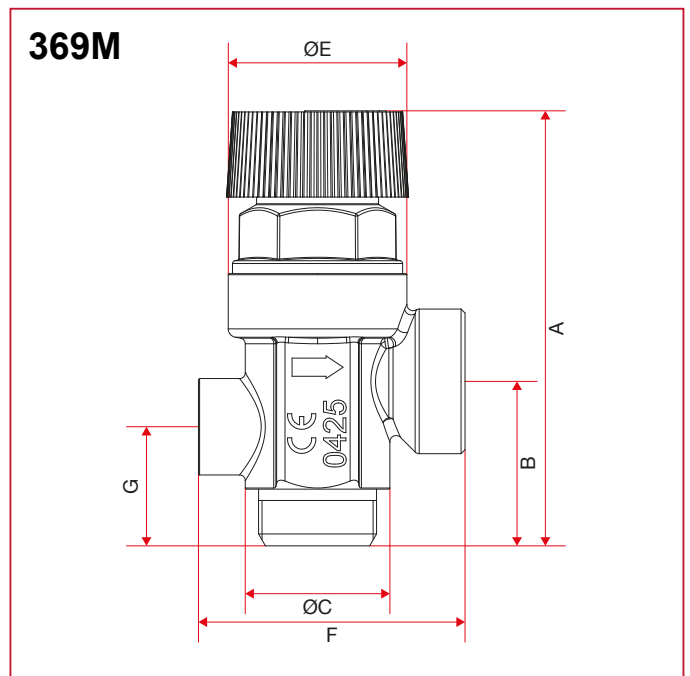

	1/2"
A	76,5
B	29
C	25,5
E	31,5
F	47
G	21



DIAPHRAGM SAFETY RELIEF VALVES (DN15 e DN20)

MATERIALS

368

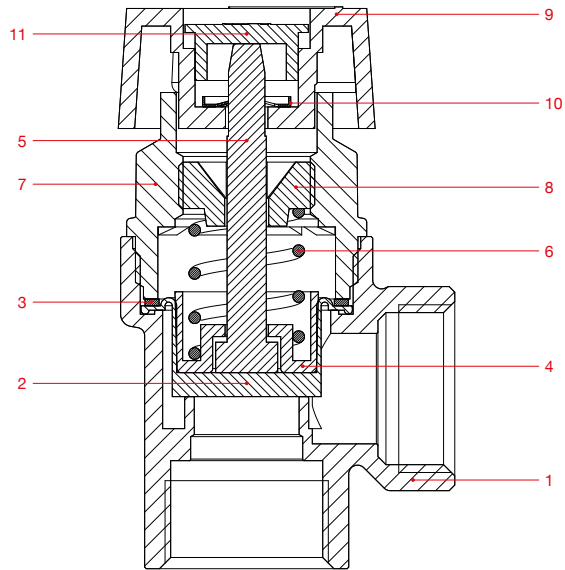

369

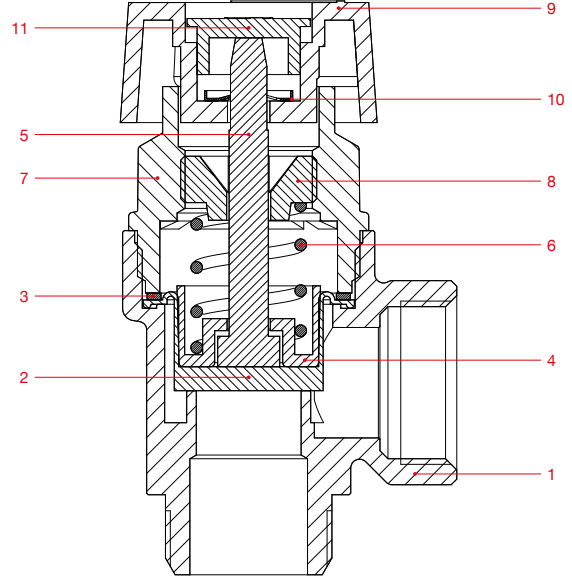

368M

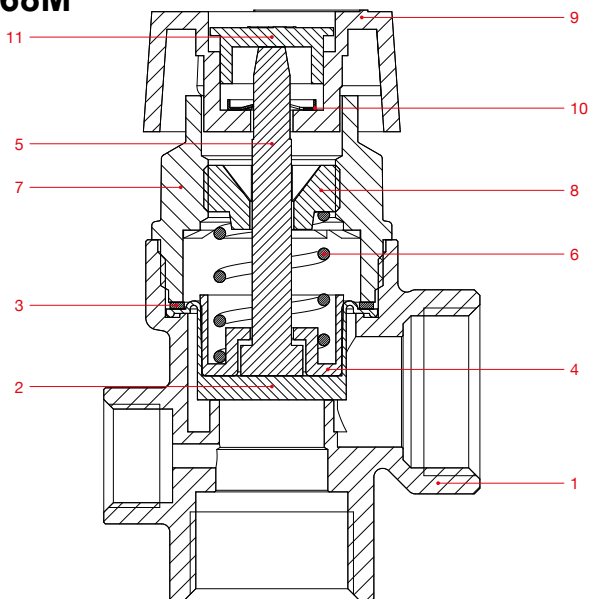

369M

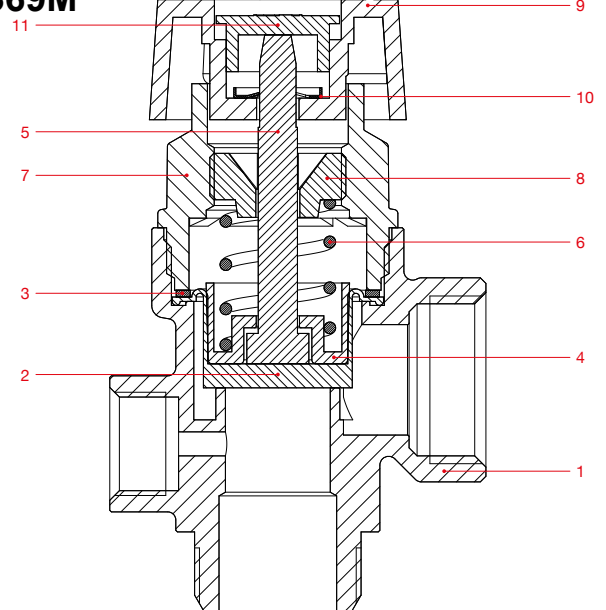

POS.	DESCRIPTION	N.	MATERIAL
1	Body	1	Brass
2	Cylindrical washer	1	EPDM
3	Washer	1	Fiber
4	Plate	1	POM
5	Stem	1	PP
6	Spring	1	Steel
7	Top lid	1	PA
8	Spring stop	1	POM
9	Handle	1	ABS
10	Seeger	1	Steel
11	Calibration cap	1	ABS



DIAPHRAGM SAFETY RELIEF VALVES (DN15 e DN20)

GENERAL FUNCTION

- **Protect the system from hazardous overpressure** that may develop within the circuits (domestic hot water, heating, etc.).
- **Automatically discharge** the fluid (typically water) to the outside when the pressure exceeds a preset limit.
- **Prevent damage** to boilers, piping, tanks, water heaters, and all other components of the system.
- **Ensure user safety** by preventing explosions or mechanical failures.

When water is heated, it expands, increasing the pressure in the circuit.

If the pressure exceeds the valve's set value, the valve opens and releases water until the pressure returns within safe limits.

FIELD OF APPLICATION

Itap valves comply with the requirements of "Raccolta R" regarding the safety of equipment containing hot liquids under pressure: *"In the case of water heaters intended for domestic use, the expansion system protecting the vessel may be implemented with a relief valve. A relief valve is defined as a counterweight or spring-loaded valve whose orifice diameter, in mm, is not less than $\sqrt{V/5}$, where V is the volume in litres of the heater, with a minimum of 15 mm."*

Code	Orifice diameter [mm]	Net section area [mm ²]	Discharge coefficient K	Set pressure [bar]	Opening overpressure [bar]	Closing overpressure [bar]
368001215	13	135	0,5	1,50	1,80	1,20
368001218	13	135	0,5	1,80	2,16	1,44
368001225	13	135	0,5	2,50	3,00	2,00
368001230	13	135	0,5	3,00	3,60	2,40
368001240	13	135	0,5	4,00	4,80	3,20
368001260	13	135	0,5	6,00	7,20	4,80
368003415	13	135	0,5	1,50	1,80	1,20
368003418	13	135	0,5	1,80	2,16	1,44
368003425	13	135	0,5	2,50	3,00	2,00
368003430	13	135	0,5	3,00	3,60	2,40
368003440	13	135	0,5	4,00	4,80	3,20
368003460	13	135	0,5	6,00	7,20	4,80
368001215M	13	135	0,5	1,50	1,80	1,20
368001218M	13	135	0,5	1,80	2,16	1,44
368001225M	13	135	0,5	2,50	3,00	2,00
368001230M	13	135	0,5	3,00	3,60	2,40
368001240M	13	135	0,5	4,00	4,80	3,20
368001260M	13	135	0,5	6,00	7,20	4,80
369001215	13	135	0,5	1,50	1,80	1,20
369001218	13	135	0,5	1,80	2,16	1,44
369001225	13	135	0,5	2,50	3,00	2,00
369001230	13	135	0,5	3,00	3,60	2,40
369001240	13	135	0,5	4,00	4,80	3,20
369001260	13	135	0,5	6,00	7,20	4,80
369001215M	13	135	0,5	1,50	1,80	1,20
369001218M	13	135	0,5	1,80	2,16	1,44
369001225M	13	135	0,5	2,50	3,00	2,00
369001230M	13	135	0,5	3,00	3,60	2,40
369001240M	13	135	0,5	4,00	4,80	3,20
369001260M	13	135	0,5	6,00	7,20	4,80



DIAPHRAGM SAFETY RELIEF VALVES (DN15 e DN20)

REQUIREMENTS FOR INSTALLING SAFETY VALVES

Before installation, the safety valve must be correctly sized by qualified technical personnel, in accordance with applicable standards and the system specifications. The valve must not be used for purposes other than those for which it was designed. Installation must be carried out exclusively by qualified personnel, following current regulations. It is essential to respect the flow direction indicated by the arrow on the valve body.

Safety valves may be installed in either vertical or horizontal position, as long as they are not upside down. This precaution prevents the accumulation of impurities that could compromise proper operation.

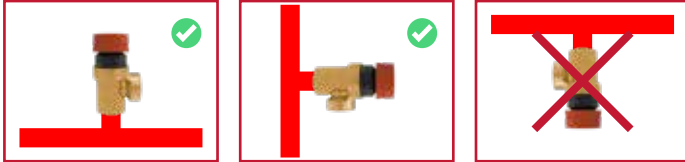

HEATING SYSTEM (Fig. 1)

Safety valves must be installed at the top of the generator or on the delivery pipe as close as possible to the generator, or within the distance "d" where specified by applicable standards. The connecting pipe between the safety valve and the generator must not contain any shut-off devices.

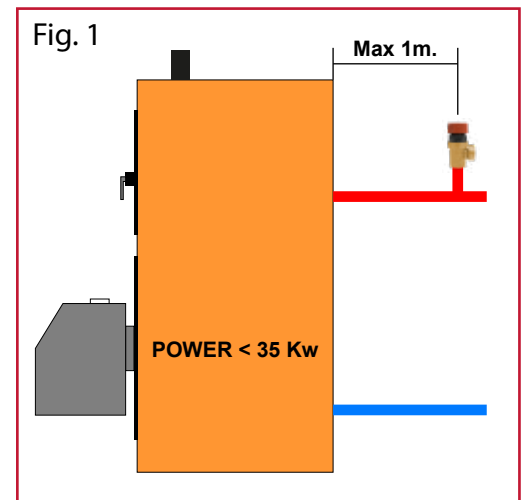

PLUMBING SYSTEM (Fig. 2)

Safety valves must be installed near the hot water storage unit, ensuring that no shut-off device is placed between the valve and the storage tank.

The maximum distance from the boiler must be 1 m, respecting the flow direction indicated by the arrow on the valve body, without any reduction, and with a diameter not smaller than the inlet section of the valve itself.

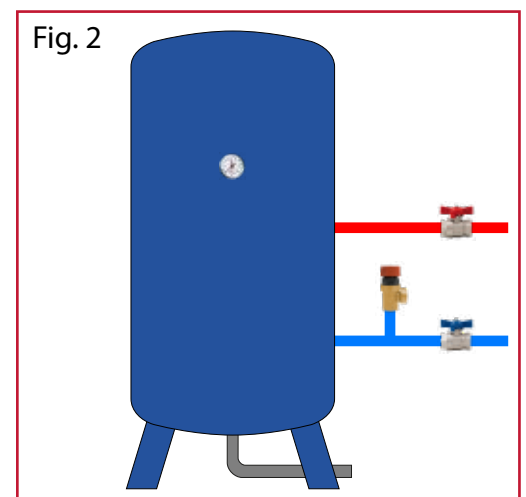

MAINTENANCE

Periodic inspection of the valve must be carried out starting from the commissioning date, according to the schedule established by current legislation, and exclusively by qualified technical personnel.

The continuous accumulation of impurities between the seat and the shutter may interfere with complete valve closure.

Regular maintenance is therefore recommended, manually operating the valve to discharge and flush the seat.

This operation must be performed by qualified technical personnel.



ITAP S.p.A.

Via Ruca 19

25065 Lumezzane

Brescia (ITALY)

Tel 030 8927011

Fax 030 8921990

www.itap.it - info@itap.it

We reserve the right to make improvements and changes to the products described herein and to the relative technical data, at any time and without forewarning.

rev.001-20260205