



TECHNICAL CATALOGUE

DIAPHRAGM SAFETY RELIEF VALVES



> THE COMPANY

ITAP SpA, founded in Lumezzane (Brescia) in 1972, is currently one of the leading production companies in Italy of **valves, fittings and distribution manifolds** for plumbing and heating systems.

Thanks to a fully automated production process, with 85 transfer machines and 55 assembly lines, it is capable of producing 400,000 pieces per day.

Our innate pursuit for innovation and observance of technical regulations is supported by the company certification ISO 9001. The company has always considered its focus on quality as the main tool to obtain significant business results: today ITAP SpA is proud to offer products bearing the approval of numerous international certifying bodies.

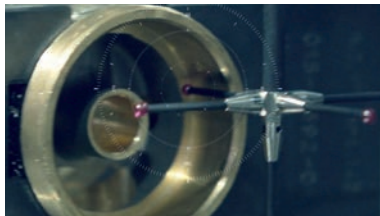
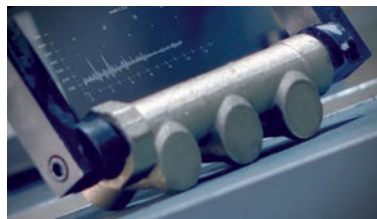
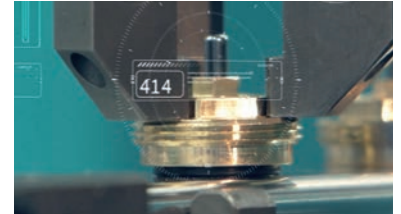
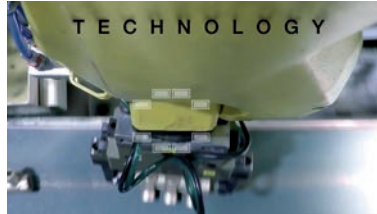

> ITAP products have obtained approvals by more than 30 certification bodies from all over the world.





DIAPHRAGM SAFETY RELIEF VALVES

368 Diaphragm safety relief valve, female/female thread



368 1/2"x1/2"

1/2"x1/2"

MEASURE	PRESSURE	CODE	PACKING
1/2" (DN 15)	1.5	368001215	10/120
1/2" (DN 15)	1.8	368001218	10/120
1/2" (DN 15)	2.5	368001225	10/120
1/2" (DN 15)	3	368001230	10/120
1/2" (DN 15)	4	368001240	10/120
1/2" (DN 15)	6	368001260	10/120

368 3/4"x3/4"

3/4"x3/4"

MEASURE	PRESSURE	CODE	PACKING
3/4" (DN 20)	1.5	368003415	10/120
3/4" (DN 20)	1.8	368003418	10/120
3/4" (DN 20)	2.5	368003425	10/120
3/4" (DN 20)	3	368003430	10/120
3/4" (DN 20)	4	368003440	10/120
3/4" (DN 20)	6	368003460	10/120

368 1"x1"

1"x1"

MEASURE	PRESSURE	CODE	PACKING
1" (DN 25)	1.5	368010015	10/80
1" (DN 25)	1.8	368010018	10/80
1" (DN 25)	2.5	368010025	10/80
1" (DN 25)	3	368010030	10/80
1" (DN 25)	4	368010040	10/80
1" (DN 25)	6	368010060	10/80

CERTIFICATIONS



TECHNICAL SPECIFICATIONS

Body in brass.

Diaphragm: EPDM.

Spring: steel.

Nominal pressure: 10 bar.

Working temperatures: 5°C - 115°C.

Opening overpressure: 20%.

Closing differential: 20%.

Available settings: 1,5 - 1,8 - 2,5 - 3 - 4 - 6 bar.



DIAPHRAGM SAFETY RELIEF VALVES

Threads: ISO 228 (equivalent to DIN EN ISO 228 and BS EN ISO 228).
The valves comply with Directive "PED" 2014/68/EU (cat. IV). (DN15-DN20)

OVERALL DIMENSIONS

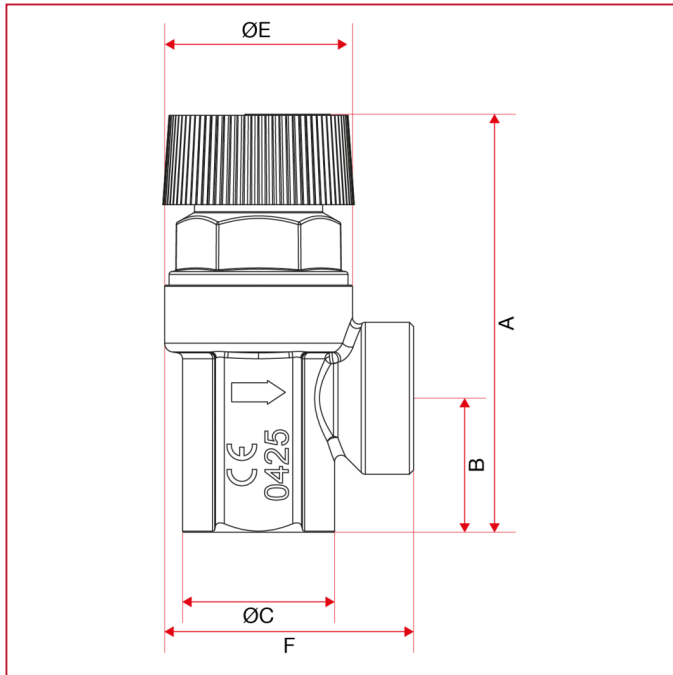

368 1/2"x1/2"

	1/2"
A	70
B	22,5
C	25,5
E	31,5
F	41,75

368 3/4"x3/4"

	3/4"
A	75
B	26,5
C	25,5
E	32
F	46

368 1"x1"

	1"
A	84
B	31,5
C	31
E	38
F	52



DIAPHRAGM SAFETY RELIEF VALVES

MATERIALS



POS.	DESCRIPTION	N.	MATERIAL
1	Body	1	Brass
2	Cylindrical washer	1	EPDM
3	Washer	1	Fiber
4	Plate	1	POM
5	Stem	1	PP
6	Spring	1	Steel
7	Top lid	1	PA
8	Spring stop	1	POM
9	Handle	1	ABS
10	Seeger	1	Steel
11	Calibration cap	1	ABS



DIAPHRAGM SAFETY RELIEF VALVES

INSTRUCTIONS ON INSTALLATION, USE AND MAINTENANCE

DIAPHRAGM SAFETY RELIEF VALVES



Art. 368



Art. 369

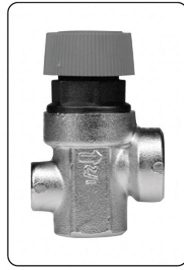

Art. 368M

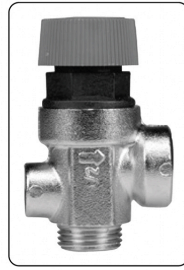

Art. 369M

The safety valves are manufactured in accordance with Directive 2014/68/EU (PED) Group IV.

Function:

Itap Spa safety valves are to be installed on heat generators, on the storage tanks of plumbing systems and more generally on water systems with pressurised fluids. Its function is to discharge part of the fluid used when the set pressure is reached into the atmosphere and to prevent the pressure inside the system from increasing beyond the permitted limits.

Safety valves have an overpressure of 20%. The designer/installer is obliged to take this into consideration during design/installation for correct dimensioning.

TECHNICAL FEATURES

Materials:

Body: Brass

Cylindrical washer: EPDM

Washer: Fibre

Plate: POM

Stem: PP

Spring: Steel

Top lid: PA

Spring stop: POM

Handle: ABS

Calibration cap: ABS

Features:

Nominal pressure: PN 10

Temperature range: 5–115°C

Opening overpressure: 20%

Closure deviation: 20%

Operating fluid: water, air

Maximum glycol percentage: 50%

Installation and Start-up:

Installation and removal must always be carried out with the system cold and not under pressure. The valve can be installed in any position except upside down and in the pipe section towards the boiler it must not be intercepted in any way (A).

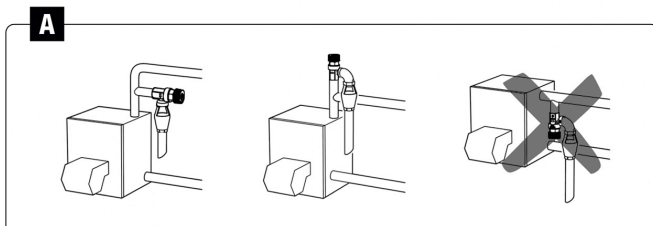



DIAPHRAGM SAFETY RELIEF VALVES

The maximum distance from the boiler must be 1 m, respecting the direction of flow indicated by the arrow on the body without any reduction, and with a diameter no smaller than that of the inlet section of the valve itself. The outlet of the safety valve must be clearly visible and conveyed in a pipe with a diameter not less than that of the outlet section of the valve itself (B).

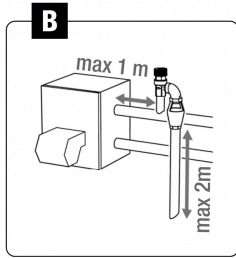

The valve must be positioned in a place which is not exposed to the risk of freezing and/or condensation.

Maintenance:

The valve must be checked annually by manually actuating the handle to cause a discharge of fluid to clean the seal seat. When making hydraulic connections, take care not to mechanically overstress the threads of the valve body. Water temperatures above 50 °C can cause severe burns.

During installation, commissioning and maintenance of safety valves, take the necessary precautions so that these temperatures do not endanger persons.

If the valve shows continuous fluid leakage or dripping, it must be checked by qualified technical personnel.

Safety:

Before installing a safety valve, it must be correctly sized by a specialised technician in accordance with the regulations in force for the specific application.

It is forbidden to use it for anything other than its intended purpose.

Installation and maintenance must be carried out by qualified technical personnel in accordance with the regulations in force.

Ensure that the connection fittings are hydraulically tight. Water temperatures above 50°C can cause severe burns.

DISPOSE OF IN ACCORDANCE WITH CURRENT REGULATIONS

This operating instruction has been drawn up in accordance with Article 3.4 Annex I of the 'PED' Directive 2014/68/EU, according to which, when placed on the market, pressure equipment must be supplied with a user leaflet containing all relevant safety information.

Declaration of conformity:





DIAPHRAGM SAFETY RELIEF VALVES

369 Diaphragm safety relief valve, male/female thread



369 1/2"x1/2"

1/2"x1/2"

MEASURE	PRESSURE	CODE	PACKING
1/2" (DN 15)	1.5	369001215	10/120
1/2" (DN 15)	1.8	369001218	10/120
1/2" (DN 15)	2.5	369001225	10/120
1/2" (DN 15)	3	369001230	10/120
1/2" (DN 15)	4	369001240	10/120
1/2" (DN 15)	6	369001260	10/120

CERTIFICATIONS



TECHNICAL SPECIFICATIONS

Body in brass.

Diaphragm: EPDM.

Spring: steel.

Nominal pressure: 10 bar.

Working temperatures: 5°C - 115°C.

Opening overpressure: 20%.

Closing differential: 20%.

Available settings: 1,5 - 1,8 - 2,5 - 3 - 4 - 6 bar.

Threads: ISO 228 (equivalent to DIN EN ISO 228 and BS EN ISO 228).

The valves comply with Directive "PED" 2014/68/EU (cat. IV).



DIAPHRAGM SAFETY RELIEF VALVES

OVERALL DIMENSIONS

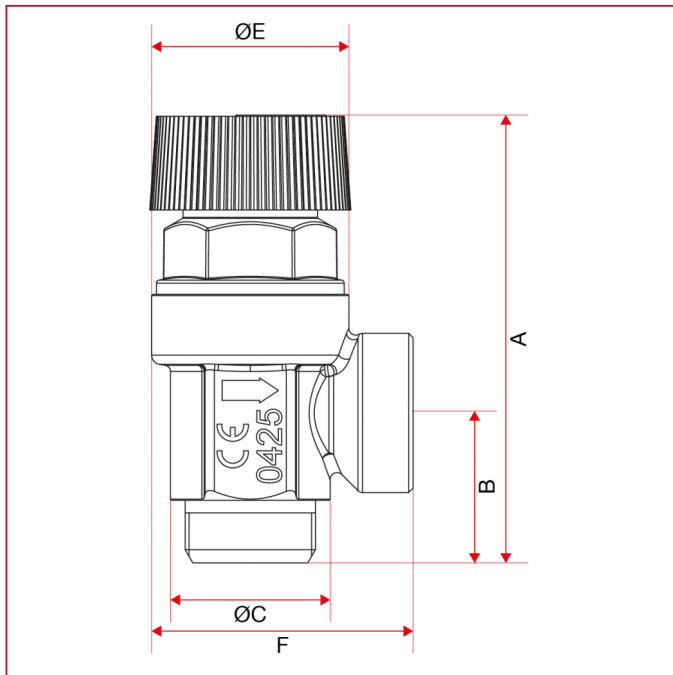

369 1/2"x1/2"

	1/2"
A	71,5
B	24
C	25,5
E	31,5
F	41,75



DIAPHRAGM SAFETY RELIEF VALVES

MATERIALS

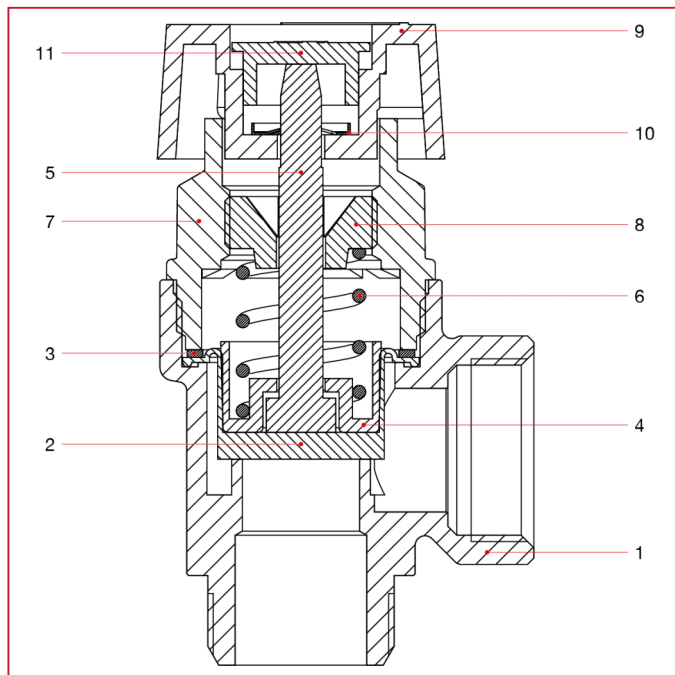

POS.	DESCRIPTION	N.	MATERIAL
1	Body	1	Brass
2	Cylindrical washer	1	EPDM
3	Washer	1	Fiber
4	Plate	1	POM
5	Stem	1	PP
6	Spring	1	Steel
7	Top lid	1	PA
8	Spring stop	1	POM
9	Handle	1	ABS
10	Seeger	1	Steel
11	Calibration cap	1	ABS



DIAPHRAGM SAFETY RELIEF VALVES

INSTRUCTIONS ON INSTALLATION, USE AND MAINTENANCE

DIAPHRAGM SAFETY RELIEF VALVES



Art. 368



Art. 369

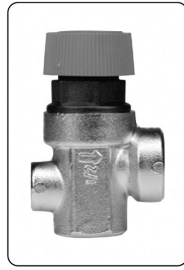

Art. 368M

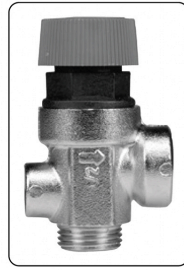

Art. 369M

The safety valves are manufactured in accordance with Directive 2014/68/EU (PED) Group IV.

Function:

Itap Spa safety valves are to be installed on heat generators, on the storage tanks of plumbing systems and more generally on water systems with pressurised fluids. Its function is to discharge part of the fluid used when the set pressure is reached into the atmosphere and to prevent the pressure inside the system from increasing beyond the permitted limits.

Safety valves have an overpressure of 20%. The designer/installer is obliged to take this into consideration during design/installation for correct dimensioning.

TECHNICAL FEATURES

Materials:

Body: Brass

Cylindrical washer: EPDM

Washer: Fibre

Plate: POM

Stem: PP

Spring: Steel

Top lid: PA

Spring stop: POM

Handle: ABS

Calibration cap: ABS

Features:

Nominal pressure: PN 10

Temperature range: 5–115°C

Opening overpressure: 20%

Closure deviation: 20%

Operating fluid: water, air

Maximum glycol percentage: 50%

Installation and Start-up:

Installation and removal must always be carried out with the system cold and not under pressure. The valve can be installed in any position except upside down and in the pipe section towards the boiler it must not be intercepted in any way (A).

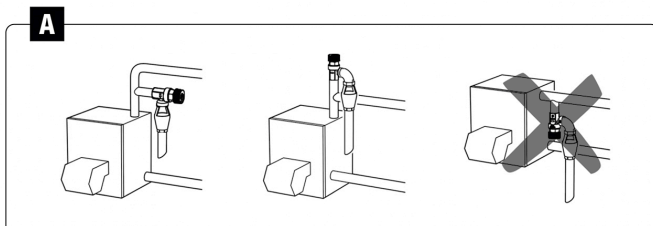



DIAPHRAGM SAFETY RELIEF VALVES

The maximum distance from the boiler must be 1 m, respecting the direction of flow indicated by the arrow on the body without any reduction, and with a diameter no smaller than that of the inlet section of the valve itself. The outlet of the safety valve must be clearly visible and conveyed in a pipe with a diameter not less than that of the outlet section of the valve itself (B).

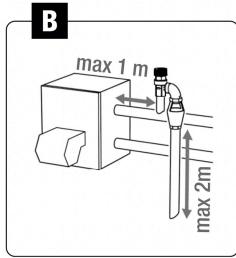

The valve must be positioned in a place which is not exposed to the risk of freezing and/or condensation.

Maintenance:

The valve must be checked annually by manually actuating the handle to cause a discharge of fluid to clean the seal seat. When making hydraulic connections, take care not to mechanically overstress the threads of the valve body. Water temperatures above 50 °C can cause severe burns.

During installation, commissioning and maintenance of safety valves, take the necessary precautions so that these temperatures do not endanger persons.

If the valve shows continuous fluid leakage or dripping, it must be checked by qualified technical personnel.

Safety:

Before installing a safety valve, it must be correctly sized by a specialised technician in accordance with the regulations in force for the specific application.

It is forbidden to use it for anything other than its intended purpose.

Installation and maintenance must be carried out by qualified technical personnel in accordance with the regulations in force.

Ensure that the connection fittings are hydraulically tight. Water temperatures above 50°C can cause severe burns.

DISPOSE OF IN ACCORDANCE WITH CURRENT REGULATIONS

This operating instruction has been drawn up in accordance with Article 3.4 Annex I of the 'PED' Directive 2014/68/EU, according to which, when placed on the market, pressure equipment must be supplied with a user leaflet containing all relevant safety information.

Declaration of conformity:





DIAPHRAGM SAFETY RELIEF VALVES

368M Diaphragm safety relief valve with pressure gauge connection, female/female thread



368M 1/2"x1/2", gauge connection 1/4"

1/2"x1/2", gauge connection 1/4"

MEASURE	PRESSURE	CODE	PACKING
1/2" (DN 15)	1.5	368001215M	10/120
1/2" (DN 15)	1.8	368001218M	10/120
1/2" (DN 15)	2.5	368001225M	10/120
1/2" (DN 15)	3	368001230M	10/120
1/2" (DN 15)	4	368001240M	10/120
1/2" (DN 15)	6	368001260M	10/120

CERTIFICATIONS



TECHNICAL SPECIFICATIONS

Body in brass.

Diaphragm: EPDM.

Spring: steel.

Nominal pressure: 10 bar.

Working temperatures: 5°C - 115°C.

Opening overpressure: 20%.

Closing differential: 20%.

Available settings: 1,5 - 1,8 - 2,5 - 3 - 4 - 6 bar.

Threads: ISO 228 (equivalent to DIN EN ISO 228 and BS EN ISO 228).

The valves comply with Directive "PED" 2014/68/EU (cat. IV).



DIAPHRAGM SAFETY RELIEF VALVES

OVERALL DIMENSIONS

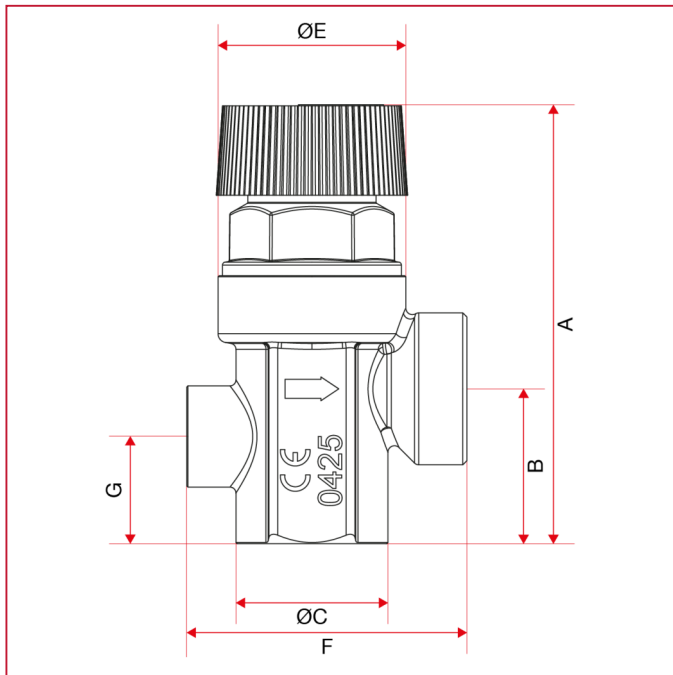

368M 1/2"x1/2", gauge connection 1/4"

	1/2"
A	73,5
B	26
C	25,5
E	31,5
F	47
G	18



DIAPHRAGM SAFETY RELIEF VALVES

MATERIALS

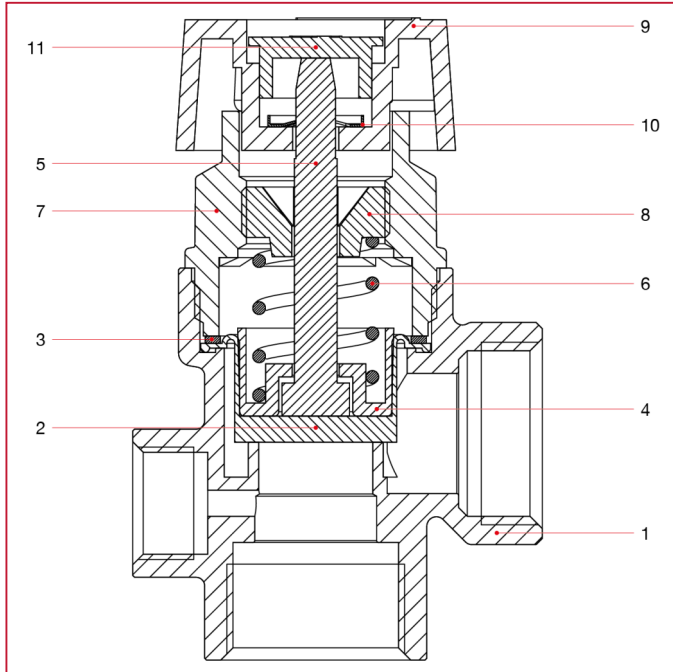

POS.	DESCRIPTION	N.	MATERIAL
1	Body	1	Brass
2	Cylindrical washer	1	EPDM
3	Washer	1	Fiber
4	Plate	1	POM
5	Stem	1	PP
6	Spring	1	Steel
7	Top lid	1	PA
8	Spring stop	1	POM
9	Handle	1	ABS
10	Seeger	1	Steel
11	Calibration cap	1	ABS



DIAPHRAGM SAFETY RELIEF VALVES

INSTRUCTIONS ON INSTALLATION, USE AND MAINTENANCE

DIAPHRAGM SAFETY RELIEF VALVES



Art. 368



Art. 369

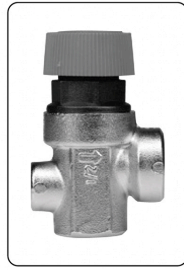

Art. 368M

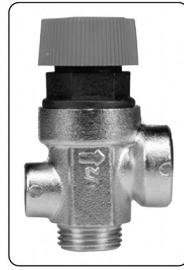

Art. 369M

The safety valves are manufactured in accordance with Directive 2014/68/EU (PED) Group IV.

Function:

Itap Spa safety valves are to be installed on heat generators, on the storage tanks of plumbing systems and more generally on water systems with pressurised fluids. Its function is to discharge part of the fluid used when the set pressure is reached into the atmosphere and to prevent the pressure inside the system from increasing beyond the permitted limits.

Safety valves have an overpressure of 20%. The designer/installer is obliged to take this into consideration during design/installation for correct dimensioning.

TECHNICAL FEATURES

Materials:

Body: Brass

Cylindrical washer: EPDM

Washer: Fibre

Plate: POM

Stem: PP

Spring: Steel

Top lid: PA

Spring stop: POM

Handle: ABS

Calibration cap: ABS

Features:

Nominal pressure: PN 10

Temperature range: 5–115°C

Opening overpressure: 20%

Closure deviation: 20%

Operating fluid: water, air

Maximum glycol percentage: 50%

Installation and Start-up:

Installation and removal must always be carried out with the system cold and not under pressure. The valve can be installed in any position except upside down and in the pipe section towards the boiler it must not be intercepted in any way (A).

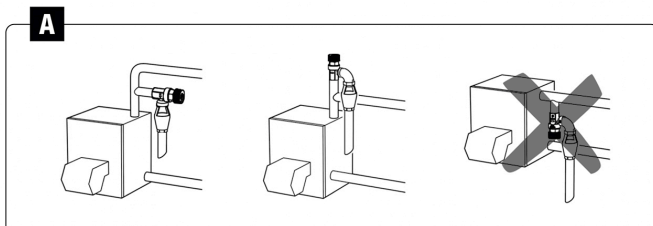



DIAPHRAGM SAFETY RELIEF VALVES

The maximum distance from the boiler must be 1 m, respecting the direction of flow indicated by the arrow on the body without any reduction, and with a diameter no smaller than that of the inlet section of the valve itself. The outlet of the safety valve must be clearly visible and conveyed in a pipe with a diameter not less than that of the outlet section of the valve itself (B).

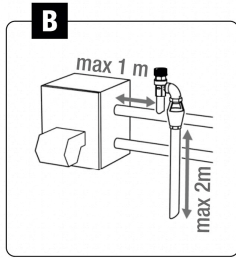

The valve must be positioned in a place which is not exposed to the risk of freezing and/or condensation.

Maintenance:

The valve must be checked annually by manually actuating the handle to cause a discharge of fluid to clean the seal seat. When making hydraulic connections, take care not to mechanically overstress the threads of the valve body. Water temperatures above 50 °C can cause severe burns.

During installation, commissioning and maintenance of safety valves, take the necessary precautions so that these temperatures do not endanger persons.

If the valve shows continuous fluid leakage or dripping, it must be checked by qualified technical personnel.

Safety:

Before installing a safety valve, it must be correctly sized by a specialised technician in accordance with the regulations in force for the specific application.

It is forbidden to use it for anything other than its intended purpose.

Installation and maintenance must be carried out by qualified technical personnel in accordance with the regulations in force.

Ensure that the connection fittings are hydraulically tight. Water temperatures above 50°C can cause severe burns.

DISPOSE OF IN ACCORDANCE WITH CURRENT REGULATIONS

This operating instruction has been drawn up in accordance with Article 3.4 Annex I of the 'PED' Directive 2014/68/EU, according to which, when placed on the market, pressure equipment must be supplied with a user leaflet containing all relevant safety information.

Declaration of conformity:





DIAPHRAGM SAFETY RELIEF VALVES

369M Diaphragm safety relief valve with pressure gauge connection, male/female thread



369M 1/2"x1/2", gauge connection 1/4"

1/2"x1/2", gauge connection 1/4"

MEASURE	PRESSURE	CODE	PACKING
1/2" (DN 15)	1.5	369001215M	10/120
1/2" (DN 15)	1.8	369001218M	10/120
1/2" (DN 15)	2.5	369001225M	10/120
1/2" (DN 15)	3	369001230M	10/120
1/2" (DN 15)	4	369001240M	10/120
1/2" (DN 15)	6	369001260M	10/120

CERTIFICATIONS



TECHNICAL SPECIFICATIONS

Body in brass.

Diaphragm: EPDM.

Spring: steel.

Nominal pressure: 10 bar.

Working temperatures: 5°C - 115°C.

Opening overpressure: 20%.

Closing differential: 20%.

Available settings: 1,5 - 1,8 - 2,5 - 3 - 4 - 6 bar.

Threads: ISO 228 (equivalent to DIN EN ISO 228 and BS EN ISO 228).

The valves comply with Directive "PED" 2014/68/EU (cat. IV).



DIAPHRAGM SAFETY RELIEF VALVES

OVERALL DIMENSIONS

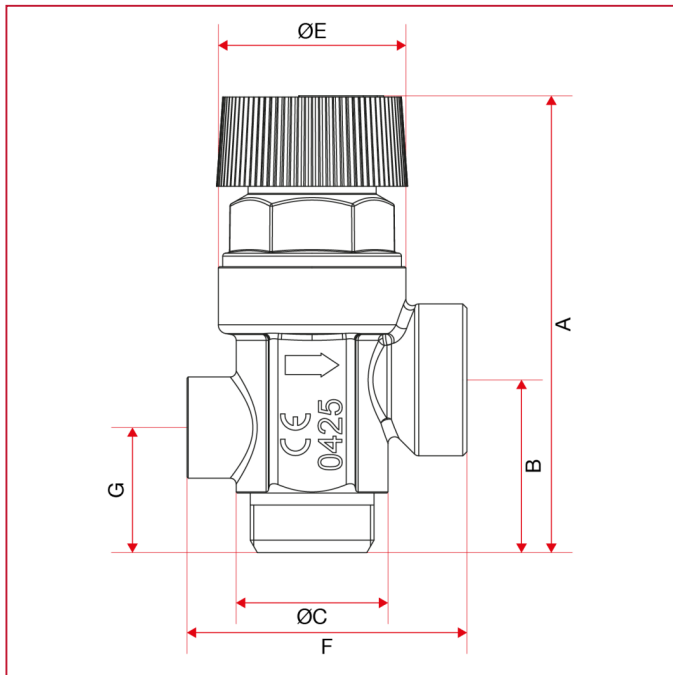

369M 1/2"x1/2", gauge connection 1/4"

	1/2"
A	76,5
B	29
C	25,5
E	31,5
F	47
G	21



DIAPHRAGM SAFETY RELIEF VALVES

MATERIALS

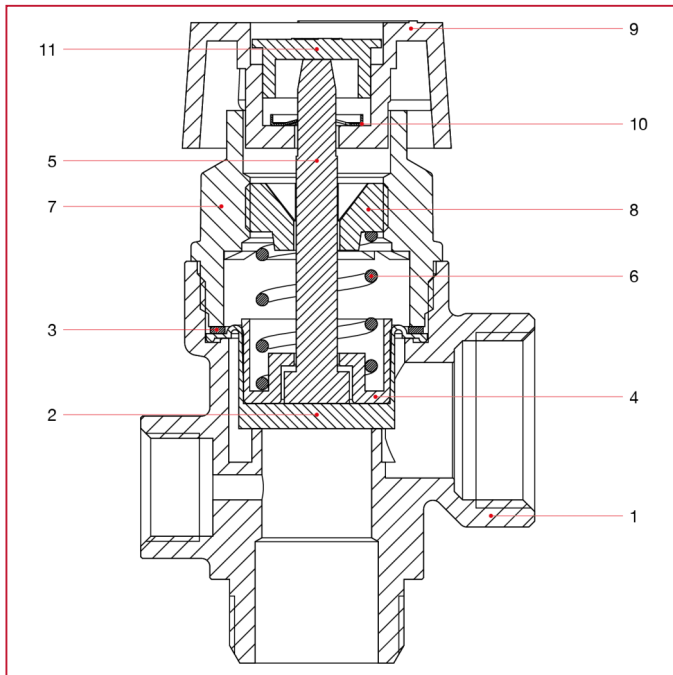

POS.	DESCRIPTION	N.	MATERIAL
1	Body	1	Brass
2	Cylindrical washer	1	EPDM
3	Washer	1	Fiber
4	Plate	1	POM
5	Stem	1	PP
6	Spring	1	Steel
7	Top lid	1	PA
8	Spring stop	1	POM
9	Handle	1	ABS
10	Seeger	1	Steel
11	Calibration cap	1	ABS



DIAPHRAGM SAFETY RELIEF VALVES

INSTRUCTIONS ON INSTALLATION, USE AND MAINTENANCE

DIAPHRAGM SAFETY RELIEF VALVES



Art. 368



Art. 369

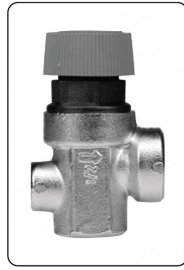

Art. 368M

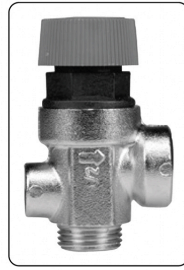

Art. 369M

The safety valves are manufactured in accordance with Directive 2014/68/EU (PED) Group IV.

Function:

Itap Spa safety valves are to be installed on heat generators, on the storage tanks of plumbing systems and more generally on water systems with pressurised fluids. Its function is to discharge part of the fluid used when the set pressure is reached into the atmosphere and to prevent the pressure inside the system from increasing beyond the permitted limits.

Safety valves have an overpressure of 20%. The designer/installer is obliged to take this into consideration during design/installation for correct dimensioning.

TECHNICAL FEATURES

Materials:

Body: Brass

Cylindrical washer: EPDM

Washer: Fibre

Plate: POM

Stem: PP

Spring: Steel

Top lid: PA

Spring stop: POM

Handle: ABS

Calibration cap: ABS

Features:

Nominal pressure: PN 10

Temperature range: 5–115°C

Opening overpressure: 20%

Closure deviation: 20%

Operating fluid: water, air

Maximum glycol percentage: 50%

Installation and Start-up:

Installation and removal must always be carried out with the system cold and not under pressure. The valve can be installed in any position except upside down and in the pipe section towards the boiler it must not be intercepted in any way (A).

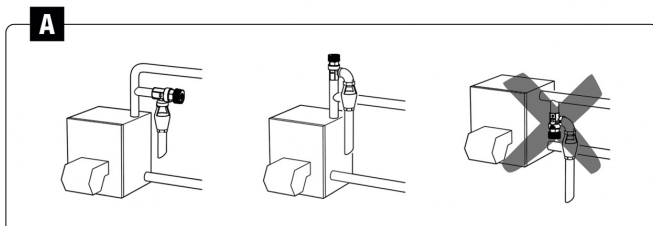



DIAPHRAGM SAFETY RELIEF VALVES

The maximum distance from the boiler must be 1 m, respecting the direction of flow indicated by the arrow on the body without any reduction, and with a diameter no smaller than that of the inlet section of the valve itself. The outlet of the safety valve must be clearly visible and conveyed in a pipe with a diameter not less than that of the outlet section of the valve itself (B).

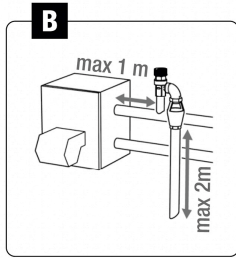

The valve must be positioned in a place which is not exposed to the risk of freezing and/or condensation.

Maintenance:

The valve must be checked annually by manually actuating the handle to cause a discharge of fluid to clean the seal seat. When making hydraulic connections, take care not to mechanically overstress the threads of the valve body. Water temperatures above 50 °C can cause severe burns.

During installation, commissioning and maintenance of safety valves, take the necessary precautions so that these temperatures do not endanger persons.

If the valve shows continuous fluid leakage or dripping, it must be checked by qualified technical personnel.

Safety:

Before installing a safety valve, it must be correctly sized by a specialised technician in accordance with the regulations in force for the specific application.

It is forbidden to use it for anything other than its intended purpose.

Installation and maintenance must be carried out by qualified technical personnel in accordance with the regulations in force.

Ensure that the connection fittings are hydraulically tight. Water temperatures above 50°C can cause severe burns.

DISPOSE OF IN ACCORDANCE WITH CURRENT REGULATIONS

This operating instruction has been drawn up in accordance with Article 3.4 Annex I of the 'PED' Directive 2014/68/EU, according to which, when placed on the market, pressure equipment must be supplied with a user leaflet containing all relevant safety information.

Declaration of conformity:





ITAP S.p.A.
Via Ruca 19
25065 Lumezzane
Brescia (ITALY)
Tel 030 8927011
Fax 030 8921990
www.itap.it - info@itap.it

We reserve the right to make improvements and changes to the products described herein and to the relative technical data, at any time and without forewarning.

rev. 20260318